

EVERPURE® KLEENSTEAM® CT

TOTAL WATER TREATMENT SYSTEM FOR STEAM APPLICATIONS.

Kleensteam CT System: EV9797-50
 4CB5 Replacement Cartridge: EV9617-16
 SS-IMF Cartridge: EV9799-32



APPLICATIONS

Commercial Steam
 Countertop Steamers

FEATURES • BENEFITS

Sophisticated Hydroblend compound prevents limescale formation in steam applications

A total system delivering high quality filtered water with cleaning and deliming capabilities

Filters incoming water to improve the performance, maximize energy efficiency and increase the life of steam equipment

Reduces chlorine-induced corrosion

System is simple to install, operate and maintain

Longer lasting SS-IMF Cartridge is more effective in higher alkalinity/hardness/TDS/temperature installations

Easy deliming with Everpure's ScaleKleen, which is fed directly into the boiler through the SR-X Bowl without boiler disassembly or the use of dangerous acids

ScaleStick is NSF® Certified under NSF/ANSI Standard 42 for material requirements only

INSTALLATION TIPS

Choose a mounting location suitable to support the full weight of the system when operating.

Use 3/8" water line.

Connect the system to the incoming cold water boiler line only. Do not connect system to the condenser.

Install vertically with cartridges hanging down.

Allow 2 1/2" (6.35 cm) clearance below the cartridge for easy cartridge replacement.

Flush cartridges by running water through system for five (5) minutes at full flow.

OPERATION TIPS

Change 4CB5 Cartridge on a regular six (6) month preventative maintenance program.

Change SS-IMF Cartridge before

Hydroblend™ compound is completely used up.

Change cartridges when capacity is

reached or when pressure falls below 10 psi (0.7 bar).

Service flow rate must not exceed 1.67 gpm (6.3 Lpm).

Always flush the filter cartridge at time of installation and cartridge change.

SIZING

Service Flow Rate: Maximum 1.67 gpm (6.3 Lpm)

EVERPURE® KLEENSTEAM® CT

EV9797-50

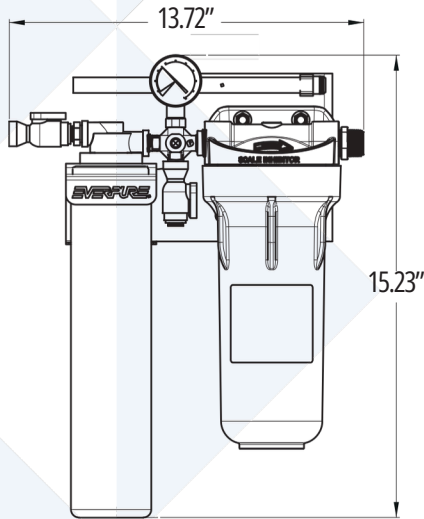

SPECIFICATIONS

Service Flow Rate

Maximum 1.67 gpm (6.3 Lpm)

Pressure Requirements

10 - 125 psi (0.7 - 8.6 bar), non-shock

Maximum Water Temperature at Inlet

80°F (27°C)

Overall Dimensions

15.23" L x 13.72" W x 6.23" D
(38.6 cm x 34.8 cm x 23.5 cm)

Inlet Connection

3/8"

Outlet Connection

3/8"

Operating Weight

18 lbs (8.1 kgs)

Shipping Weight

15 lbs (6.8 kgs)

Electrical Connection

None required

Alkalinity Range

2 to 12 grains per gallon

WARRANTY

Everpure water treatment systems by Pentair® (excluding replaceable elements) are covered by a limited warranty against defects in material and workmanship for a period of five years after date of purchase. Everpure replaceable elements (filter cartridges and water treatment cartridges) are covered by a limited warranty against defects in material and workmanship for a period of one year after date of purchase. See printed warranty for details. Pentair will provide a copy of the warranty upon request.

The contaminants or other substances removed or reduced by this drinking water system are not necessarily in your water. Do not use with water that is microbiologically unsafe or of unknown quality without adequate disinfection before or after the system.



WATER QUALITY SYSTEMS

EVERPURE-SHURFLO WORLD HEADQUARTERS, 1040 MUIRFIELD DRIVE, HANOVER PARK, IL 60133 USA • FOODSERVICE.PENTAIR.COM
800.942.1153 (US ONLY) • 630.307.3000 MAIN • 630.307.3030 FAX • CSEVERPURE@PENTAIR.COM EMAIL

EVERPURE-SHURFLO AUSTRALIA, 1-21 MONASH DRIVE, DANDENONG SOUTH, VIC 3175 AUSTRALIA
011.1300.576.190 TEL • 011.61.39.562.7237 FAX • AU.EVERPURE@PENTAIR.COM EMAIL

EVERPURE-SHURFLO CHINA, 21F CLOUD 9 PLAZA, NO 1118, SHANGHAI, 200052, CHINA
86.21.3211.4588 TEL • 86.21.3211.4580 FAX • CHINA.WATER@PENTAIR.COM EMAIL

EVERPURE-SHURFLO INDIA, GREEN BOULEVARD, B-9/A, 7TH FLOOR - TOWER B SECTOR 62, NOIDA - 201301
91.120.419.9444 TEL • 91.120.419.9400 FAX • INDIACUSTOMER@PENTAIR.COM EMAIL

EVERPURE-SHURFLO EUROPE, PENTAIR WATER BELGIUM BVBA, INDUSTRIEPARK WOLFSTEE, TOEKOMSTLAAN 30, B-2200 HERENTALS, BELGIUM
+32.(0).14.283.504 TEL • +32.(0).14.283.505 FAX • SALES@EVERPURE-EUROPE.COM EMAIL

EVERPURE-SHURFLO JAPAN INC., HASHIMOTO MN BLDG. 7F, 3-25-1 HASHIMOTO, MIDORI-KU, SAGAMIHARA-SHI KANAGAWA 252-0143, JAPAN
81.(0)42.775.3011 TEL • 81.(0)42.775.3015 FAX • INFO@EVERPURE.CO.JP EMAIL

EVERPURE-SHURFLO SOUTHEAST ASIA, 390 HAVELOCK ROAD, #04-01 KING'S CENTRE, SINGAPORE 169662
65.6768.5800 TEL • 65.6737.5149 FAX • CSEVERPURE@PENTAIR.COM EMAIL

All Pentair trademarks and logos are owned by Pentair, Inc. or its affiliates. All other registered and unregistered trademarks and logos are the property of their respective owners. Because we are continuously improving our products and services, Pentair reserves the right to change specifications without prior notice. Pentair is an equal opportunity employer.

Authorized distributor

Aquality Intelligent Solutions Pvt. Ltd



8-1-284/OU/566, 2nd Floor, OU Colony, Shaikpet, Hyderabad,
Telangana, India, 500008

+91 70938 98486 | sales@aquality.in | aquality.co.in