

EVERPURE® claris™ GEN2 3/8" BSP HEAD

DESIGNED EXCLUSIVELY FOR USE WITH CLARIS REPLACEMENT CARTRIDGES

Clariss Gen2 3/8" BSP Head: EV4339-90



APPLICATIONS

Coffee and Espresso
 Hot Drink Vending
 Combi Steamers and Self-Cooking Systems

Steam Cookers and Ovens
 Brewed Iced Tea

FEATURES • BENEFITS

Commercial-quality filter head is designed exclusively to fit Claris filter cartridges
 Solid, durable construction is ideal for foodservice and vending applications
 Engineered for durability, strength and longevity
 Corrosion-resistant hardware
 Tamper proof bypass settings

HEAD FEATURES:

- Fast change out - locks with only a 45° turn
- Built-in flush port
- Auto shut-off
- Quick and easy adjustable bypass; key provided
- Flow restrictor
- Backflow restrictor

System can be operated horizontally or vertically, depending on the space available

INSTALLATION TIPS

The system can be operated freestanding, lying horizontally or mounted vertically.

If mounting vertically to a wall, securely connect the mounting bracket to the wall using suitable screws. Water pressure at

the filter system inlet must not exceed 116 psi (8 bar). A pressure reducer valve must be installed on the water supply side of the filter system if the inlet pressure exceeds 116 psi (8 bar). Shut-off valve must be installed upstream of the filter.

Refer to Installation, Operation & Maintenance Manual for cartridge flushing and startup.

OPERATION TIPS

Change Claris cartridge when its pre-calculated water volume has been reached or at least once a year.

Change cartridges when capacity is reached.

Always flush the filter cartridge at time of installation and cartridge change. Do not use hardness test strips to check for hardness reduction, please use titration kit to check for hardness reduction.

EVERPURE® claris™ GEN2 3/8" BSP HEAD

EV4339-90

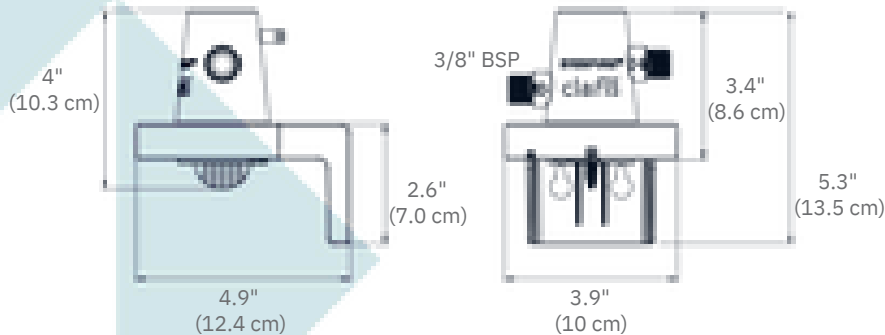

SPECIFICATIONS

Overall Dimensions:

5.3" H x 3.9" W x 4.9" D
(13.5 cm x 10 cm x 12.4 cm)

Electrical Connection:

None required

Claris™ is a trademark of Aquis, GmbH

WARRANTY

Everpure Claris water treatment systems (excluding replaceable elements) are covered by a limited warranty against defects in material and workmanship for a period of one year after date of purchase. Everpure replaceable elements (filter cartridges and water treatment cartridges) are covered by a limited warranty against defects in material and workmanship for a period of one year after date of purchase. See printed warranty for details. Everpure will provide a copy of the warranty upon request.



Authorized distributor

Aquality Intelligent Solutions Pvt. Ltd



8-1-284/OU/566, 2nd Floor, OU Colony, Shaikpet, Hyderabad,
Telangana, India, 500008

+91 70938 98486 | sales@aquality.in | aquality.co.in

WATER QUALITY SYSTEMS EVERPURE-SHURFLO WORLD HEADQUARTERS, 1040 MUIRFIELD DRIVE, HANOVER PARK, IL 60133 USA • FOODSERVICE.PENTAIR.COM
800.942.1153 MAIN (US ONLY) • 630.307.3000 MAIN • 630.307.3030 FAX • CSEVERPURE@PENTAIR.COM EMAIL

EVERPURE-SHURFLO AUSTRALIA, 1-21 MONASH DRIVE, DANDENONG SOUTH, VIC 3175, AUSTRALIA
011.1300.576.190 TEL • 011.61.39.562.7237 FAX • AU.EVERPURE@PENTAIR.COM EMAIL

EVERPURE-SHURFLO CHINA, 21F CLOUD 9 PLAZA, NO 1118, SHANGHAI, 200052, CHINA
86.21.3211.4588 TEL • 86.21.3211.4580 FAX • CHINA.WATER@PENTAIR.COM EMAIL

EVERPURE-SHURFLO INDIA, GREEN BOULEVARD, B-9/A, 7TH FLOOR - TOWER B SECTOR 62, NOIDA - 201301

91.120.419.9444 TEL • 91.120.419.9400 FAX • INDIACUSTOMER@PENTAIR.COM EMAIL

EVERPURE-SHURFLO EUROPE, PENTAIR WATER BELGIUM BVBA, INDUSTRIEPARK WOLFSTEE, TOEKOMSTLAAN 30, B-2200 HERENTALS, BELGIUM
+32.(0).14.283.504 TEL • +32.(0).14.283.505 FAX • SALES@EVERPURE-EUROPE.COM EMAIL

EVERPURE-SHURFLO JAPAN INC., HASHIMOTO MN BLDG. 7F, 3-25-1 HASHIMOTO, MIDORI-KU, SAGAMIHARA-SHI KANAGAWA 252-0143, JAPAN

81.(0)42.775.3011 TEL • 81.(0)42.775.3015 FAX • INFO@EVERPURE.CO.JP EMAIL

EVERPURE-SHURFLO SOUTHEAST ASIA, SOUTHEAST ASIA, 390 HAVELOCK ROAD, #04-01, KING'S CENTRE, SINGAPORE 169662

65.6768.5800 TEL • 65.6737.5149 FAX • CSEVERPURE@PENTAIR.COM EMAIL

All Pentair trademarks and logos are owned by Pentair, Inc. or its affiliates. All other registered and unregistered trademarks and logos are the property of their respective owners. Because we are continuously improving our products and services, Pentair reserves the right to change specifications without prior notice. Pentair is an equal opportunity employer.

© 2016 Pentair Filtration Solutions, LLC. All Rights Reserved.